

- 1 Gas inlet
- 2 Micro wave guide
- 3 Microwave cavity
- 4 Chamber
- 5 Exhaust
- 6 Thermocouple

16160510-16E1622E160

Fig. 1

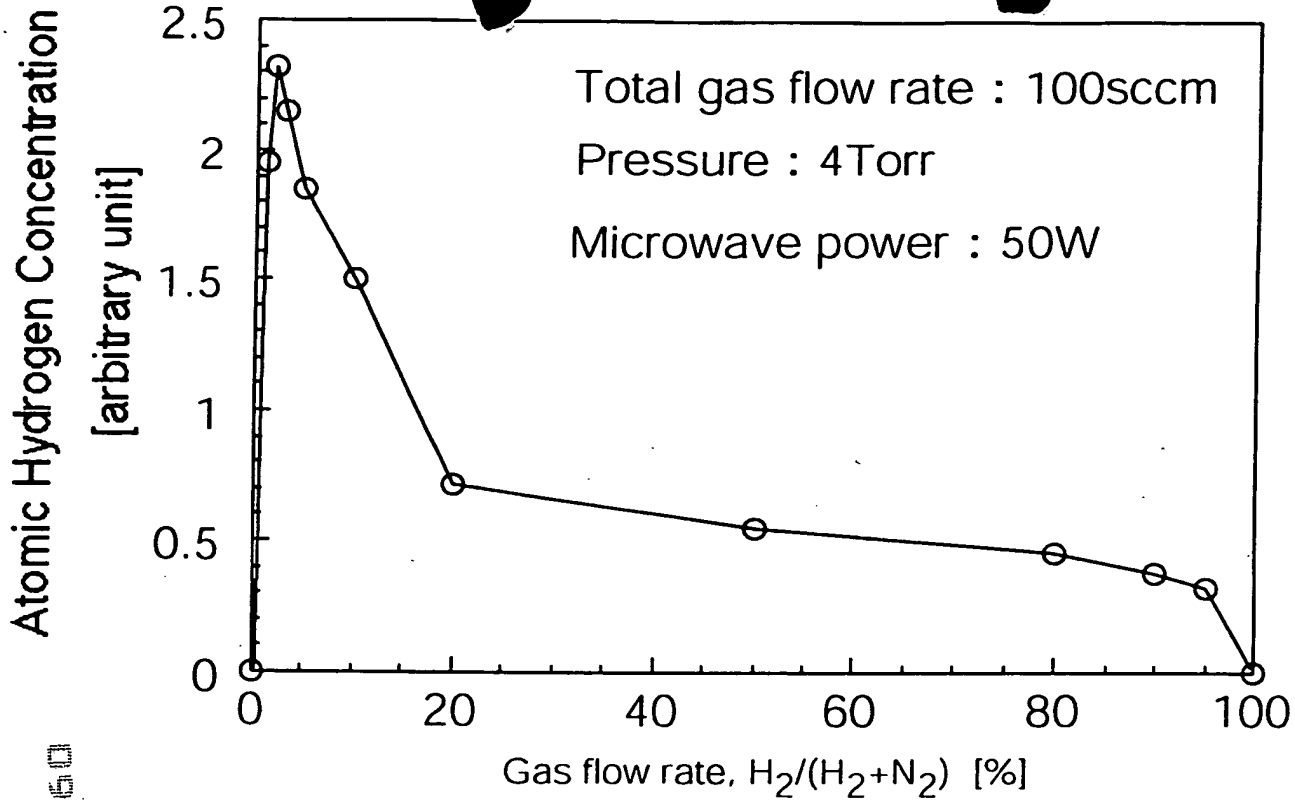

66090-6E5B2E60

Fig. 2

666090*6682E60

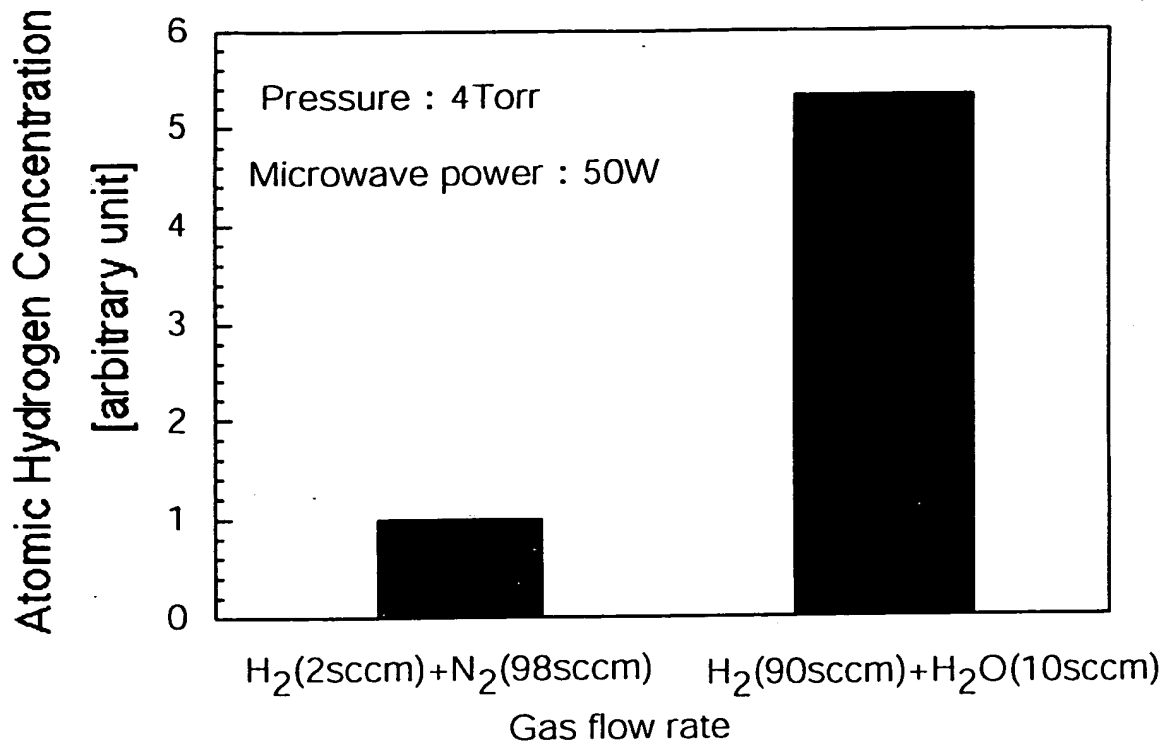

Fig. 3

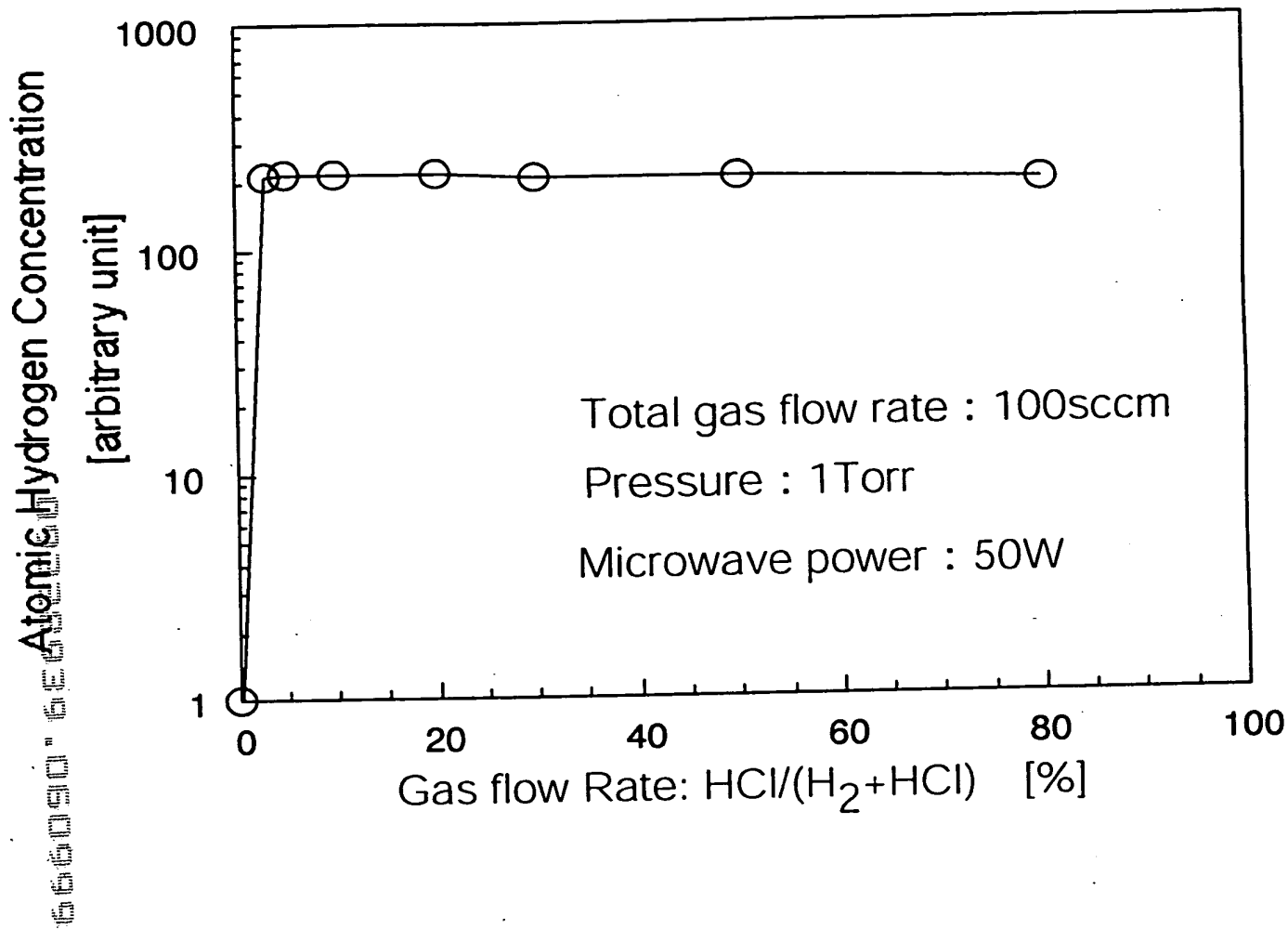

Fig. 4

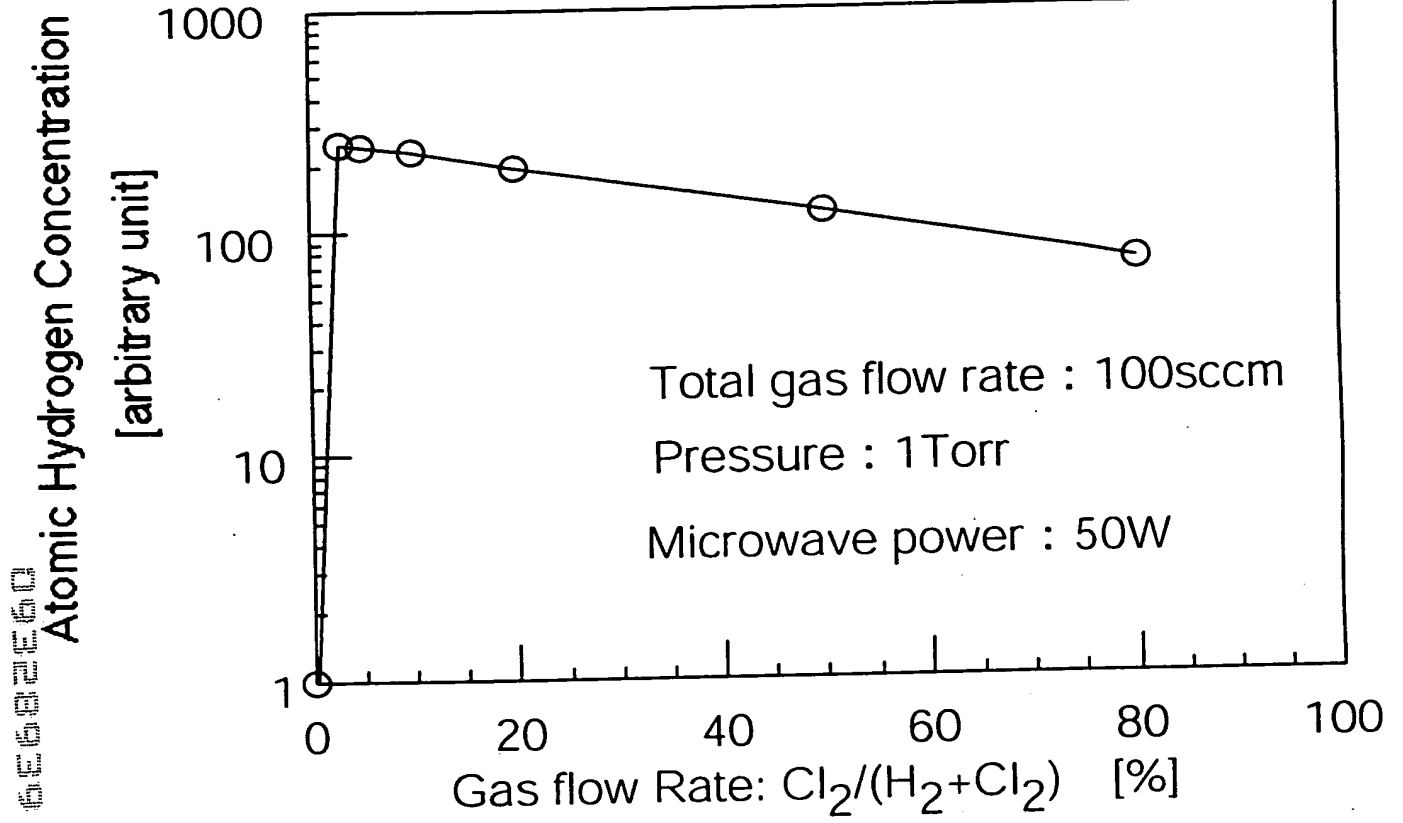

Fig. 5

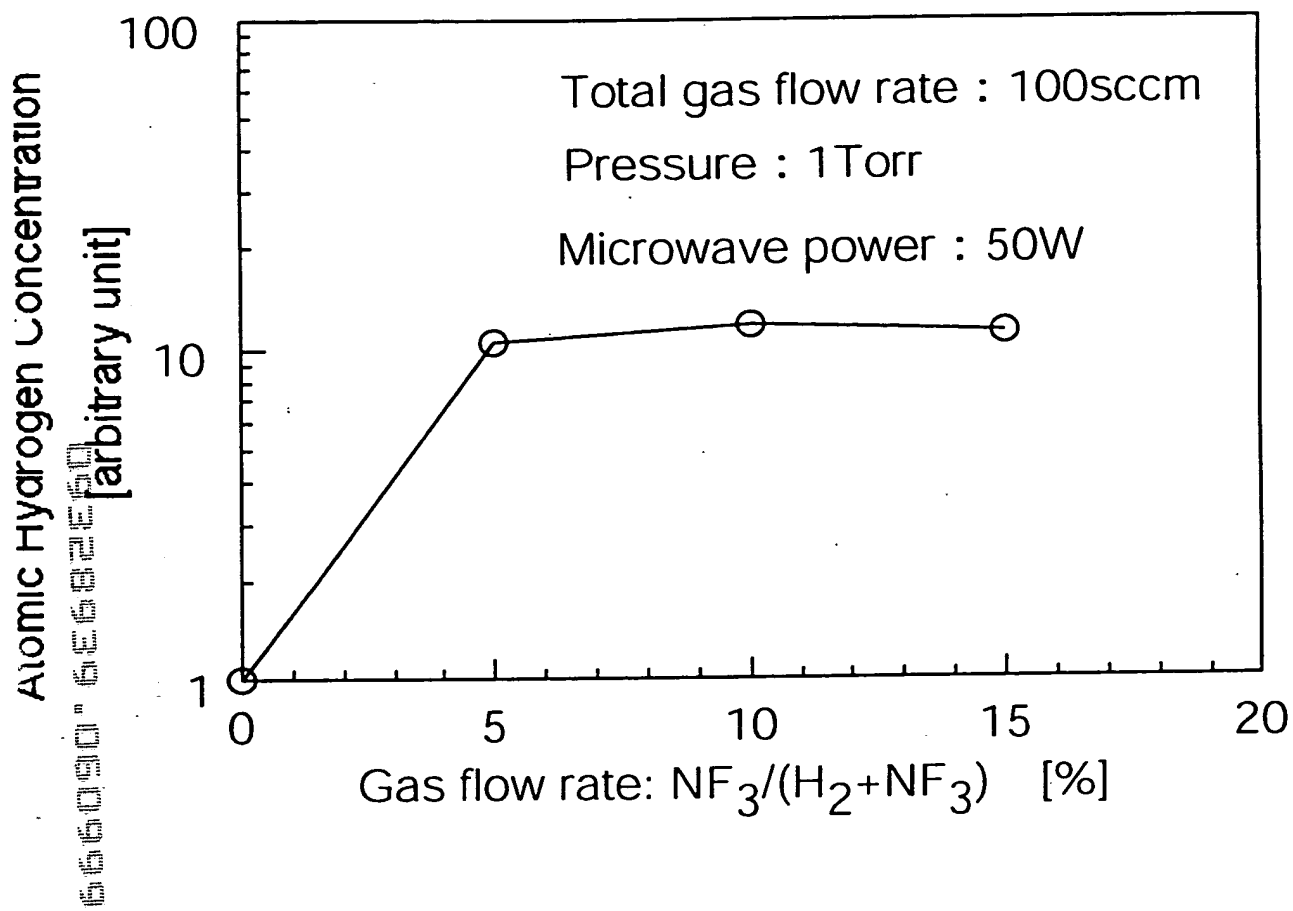
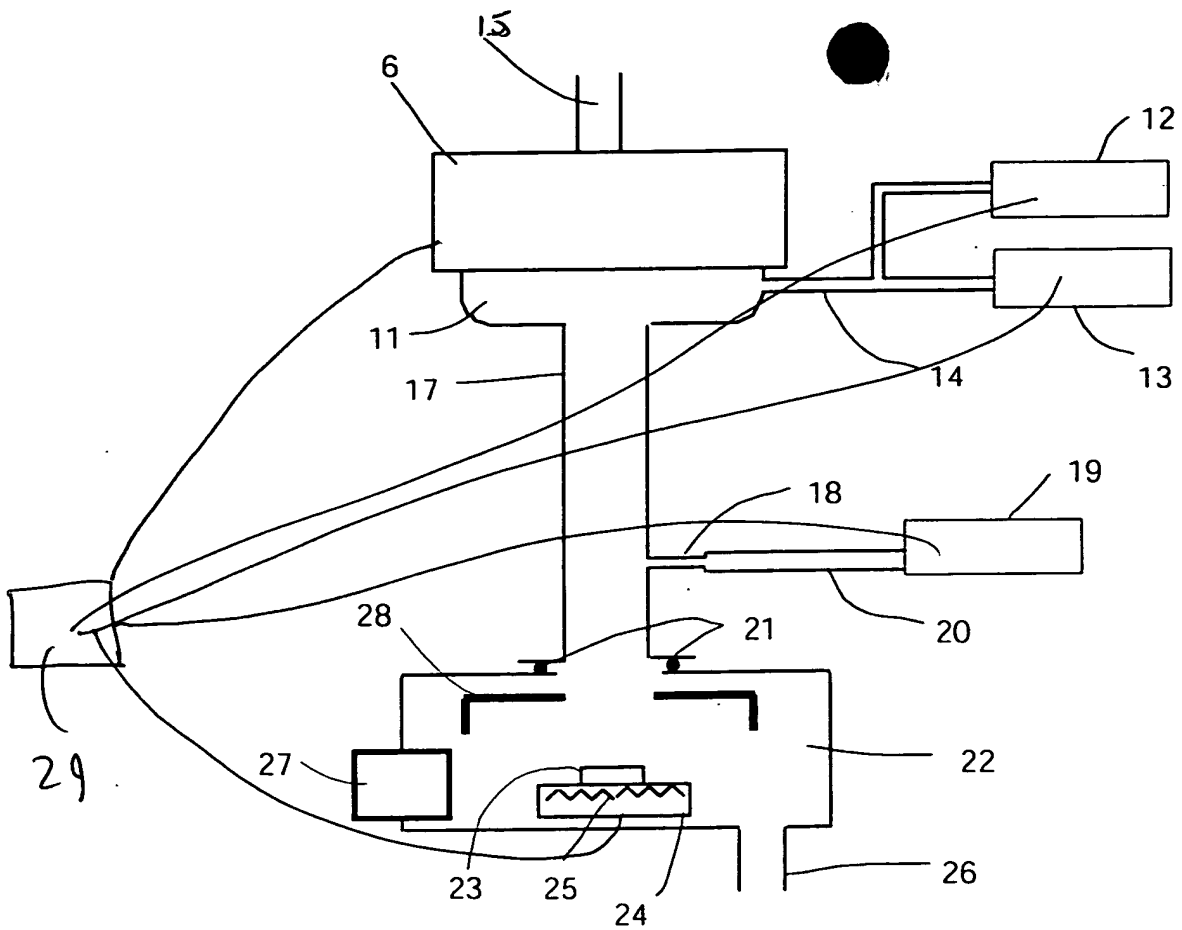

Fig. 6



- 11 Plasma discharge room
- 12 Gas-A supply unit
- 13 Gas-B supply unit
- 14 Fitting
- 15 Microwave generator
- 16 Wave guide
- 17 Microwave cavity
- 18 Nozzle
- 19 Gas-D supply unit
- 20 Fitting
- 21 O-ring
- 22 Treatment room
- 23 Treatment material
- 24 Treatment stage
- 25 SiC heater unit
- 26 Vacuum Exhaust port
- 27 Loading & Unloading port
- 28 Inside wall

Fig. 7

66090" 668260

66090-6682E60

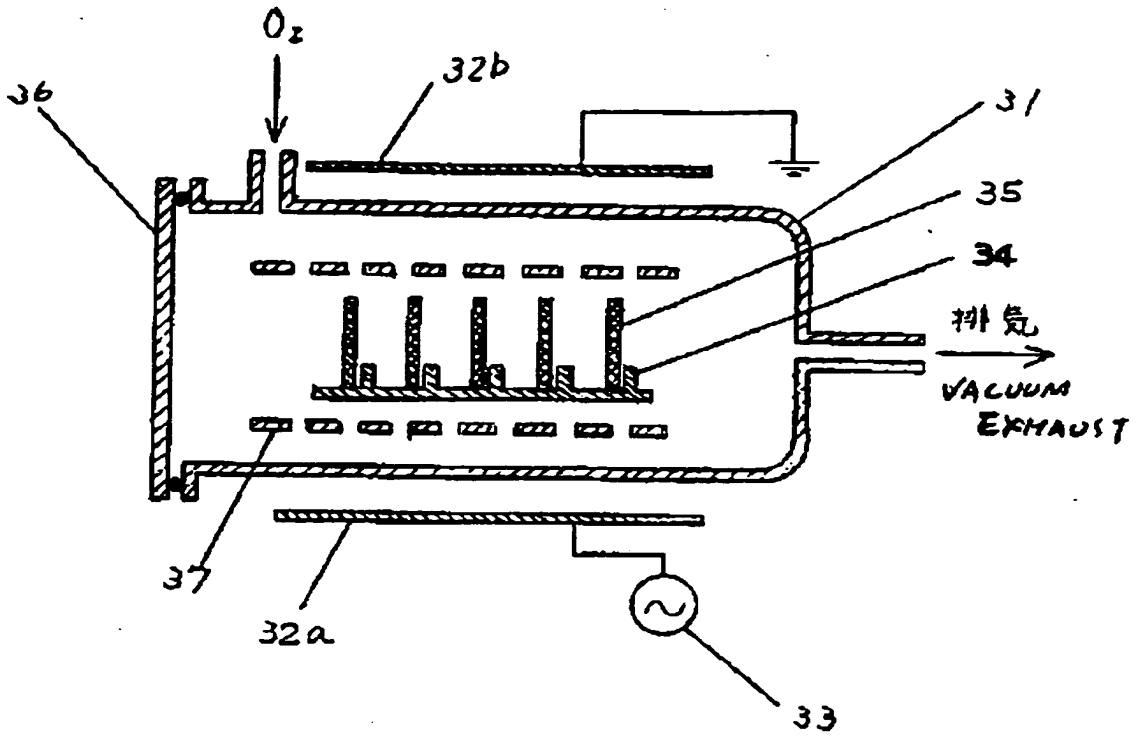

Fig. 8